



50Ω TERMINATED 3GHz N LATCHING S.P.4 T. SWITCH

OPTIONS: INDICATOR / TTL DRIVE / SUPP.DIODES

R F CHARACTERISTICS

NUMBER OF WAYS : 4
FREQUENCY RANGE : 0 - 3 GHz
IMPEDANCE : 50 Ohms

FREQUENCY (GHz)	0 - 3
V.S.W.R	<= 1.20
INSERT. LOSS <=	0.20 dB
ISOLATION >=	80 dB
AVER. POWER (*)	400 W

TERMINATION IMPEDANCE : 50 Ohms
TERMINATION AVG. POWER AT 25° C : 1 W per termination
3 W total power

ELECTRICAL CHARACTERISTICS

ACTUATOR : LATCHING
NOMINAL CURRENT AT 25° C (*10%) : 320 mA / RESET : 1280 mA (**)
ACTUATOR VOLTAGE (Vcc) : 12V (10.2 to 13V) / NEGATIVE COMMON
TERMINALS : solder pins (250°C max./30 sec.)
INDICATOR RATING : 1 W / 30 V / 100 mA
TTL INPUTS (E) - High level : 2.2 to 5.5V / 800µA at 5V
- Low level : 0 to 0.8V / 20µA at 0.8V

MECHANICAL CHARACTERISTICS

CONNECTORS : N female per MIL-C 39012
LIFE : 2.000.000 cycles per position
SWITCHING TIME (nominal voltage;25° C) : < 15 ms
CONSTRUCTION : splashproof
WEIGHT : < 460 g

ENVIRONMENTAL CHARACTERISTICS

OPERATING TEMPERATURE RANGE (°C) : -40 , +85
STORAGE TEMPERATURE RANGE (°C) : -55 , +85

(* : average power at 25° C per RF path)
(** RESET : supply voltage time 1sec. max./duty cycle 10%)

This information is given as an indication. In the continual goal to improve our products, we reserve the right to make any modifications judged necessary

4112-9212

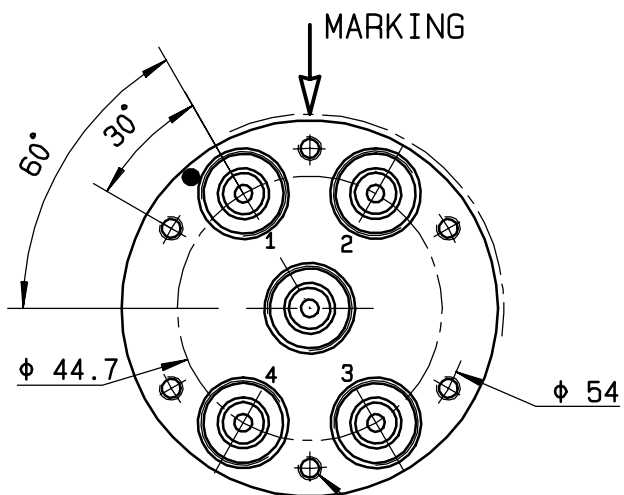

TTL input	RF continuity	Ind.
RESET = 1	All ports open	--
E1 = 1	IN ↔ 1	D.E
E2 = 1	IN ↔ 2	D.F
E3 = 1	IN ↔ 3	D.G
E4 = 1	IN ↔ 4	D.H

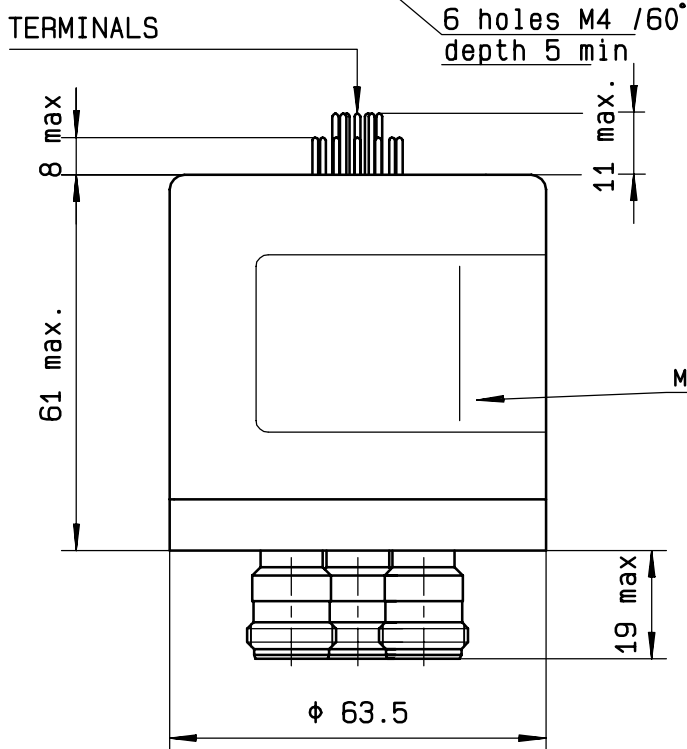

MARKING TOP VIEW (TERMINALS)

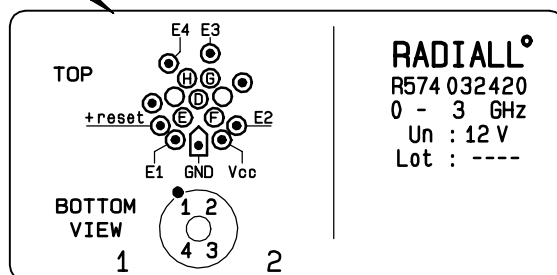

RADIALL
 R574 032420
 0 - 3 GHz
 Un : 12 V
 Lot : ----

SCHEMATIC DIAGRAM

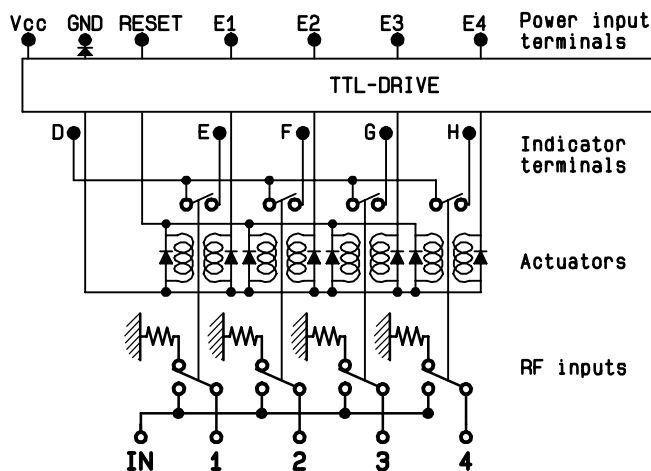

This information is given as an indication. In the continual goal to improve our products, we reserve the right to make any modifications judged necessary

4113-9212